

Specification sheet

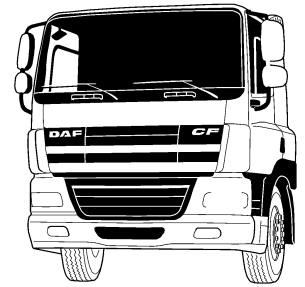

A **PACCAR** COMPANY

FTT CF85 6x4 tractor, Airglider



Engines

CF85.510; 375 kW

GVM¹⁾

25600 kg

GCM²⁾

58000 kg

Max. front³⁾: 7500 kg

Max. rear: 18100 kg

	Wheelbase - AE		Unladen weight ⁴⁾			Gross Carrying Capacity			Variable dimensions									
	WB	AE	Front	Rear	Total	Front	Rear	Total	AC	CE	CH ⁵⁾	KA ⁶⁾	KA ⁶⁾	TL	HA ⁷⁾	HA ⁹⁾	TK ⁹⁾	TW ¹⁰⁾
Day	4.30	1.63	4700	2860	7560	1300	12140	13440	0.39	5.54	1.96	0.42	0.42	7.31	0.97	0.95	14.62	16.10
Sleeper	4.30	1.63	4820	2860	7680	1180	12140	13320	0.82	5.11	1.96	0.38	0.38	7.31	0.97	0.95	14.62	16.10
Space	4.30	1.63	4870	2860	7730	1130	12140	13270	0.82	5.11	2.63	0.37	0.37	7.31	0.97	0.95	14.62	16.10

Other dimensions VA: 1.38 WT: 1.37 HV¹¹⁾: 0.93 HV¹²⁾: 0.9 1 RB: 0.86 SB: 1.84 TB: 2.45

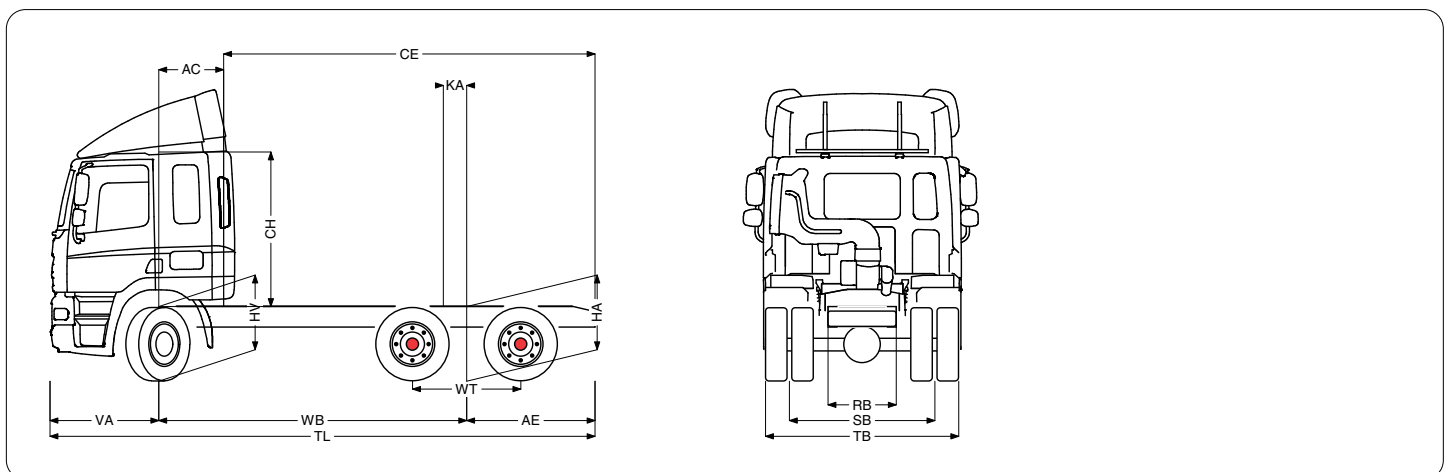

- 1) GVM in conformity with registration documents.
- 2) GCM in conformity with registration documents.
- 3) Axle load with standard tyre size.
- 4) Chassis and Cab Weight calculated with: Standard specification items only with 0 litres of fuel, 15 litres of AdBlue and driver of 0 kg, tolerance $\pm 3\%$. Changing of the specification can have major impact on vehicle weight.
- 5) Cab height is measured from frame member to closed cabin roof hatch. With air intake on cab roof: +0.14 m.

- 6) Calculate customer specific KA with TOPEC.
- 7) Unladen height at centre of driven axle(s).
- 8) Laden height at centre of driven axle(s).
- 9) TK = turning circle between kerbs.
- 10) TW = turning circle between walls.
- 11) Unladen height at centre of front axle(s).
- 12) Laden height at centre of front axle(s).

TOPEC III V6.8 201501a (10951)

FTT CF85

6x4 tractor, Airglider

Cab exterior

Mechanically suspended Sleeper Cab with steel bumper, tinted glass and electric window openers. Main mirrors and wide angle mirrors electrically heated. Cab width 2300 mm; central door lock system. Door lock switch for the co-driver door on the dashboard. Includes 2 remote control units and 2 transponder keys; translucent external sun visor above the windscreen, colour green; main mirrors convex; electrical adjustment of the main mirrors and the wide angle mirrors; bi-reflector halogen head lights with impact-resistant Lexan lens. Head light levelling device; combi lights (fog lamps and spot lamps) in the bumper; single air horn set, consisting of two horns on the cab roof, with pulling chord in the cab.

Optional:

- Sleeper Cab, mechanical suspension
- Space Cab, mechanical suspension

Aerodynamics

Adjustable aerodynamically shaped roof spoiler with top collar and side collars.

Cab interior

Right-hand drive; air bag in the steering wheel. Seat belt tensioners for the driver and co-driver seats; steering wheel black, soft grip black finish; black coloured finish for the active zones of the dashboard; air suspended driver seat - Comfort Air. High backed seat. Upholstery Flash Copper for the seat facing, Thunder for the borders and Rustico for the edges; storage box on the engine tunnel; sleeping compartment with lower bunk raised 250 mm above the engine tunnel. Storage facilities under the bunk, at upper level: 3 open boxes (total volume 260 litres) accessible with tilted bunk. At lower level: airtight box 85 litres with external hatch (left-hand side) and storage box 85 litres accessible with tilted bunk (right-hand side); manually controlled aircro with air recirculation; pollen filter. Effectiveness 85% for particles up to 0.5 micron and 98% for particles up to 10 micron; converter 24V to 12V, 20A, 240W.

Optional:

- Dashboard: wood structure
- Driver seat: Luxury Air
- Refrigerator
- Auxiliary cab heater (air)
- Auxiliary cab heater (air) with timer

Communication and driving management

Universal FMS (Fleet Management System) connector with wiring, to read information as defined in the truck manufacturers' FMS standard; basic radio/USB player. Speaker system with 2 speakers; handsfree telephone kit. Includes steering wheel button functions for telephone call start/stop, redial last numbers and phone book. Telephone information display on the LCD screen in the instrument panel; standard antennas: AM/FM, GSM and GPS. Second GSM antenna for telephone. Extra antenna: CB; cruise control.

Suspension and axles

Front axle type 152N, 100 mm vertical offset. Parabolic leaf suspension with shock absorbers and stabiliser. Max. load 7.5 tonnes; type MT23-165 double driven rear tandem axles with single reduction. Lockable inter-axle and cross-axle differentials.

The two tandem axles are each suspended with 4 air bellows and include shock absorbers and a stabiliser. Max. load 2 x 9.0 tonnes.

Optional:

- Rear: 2x 9.00 t, air suspension, MT21-144

Wheels and tyres

Front axle: tyre size 275/70R22.5, wheel size 22.5 x 8.25; rear axles: tyre size 275/70R22.5, wheel size 22.5 x 8.25; supplier Goodyear; disc wheels aluminium, Alcoa Brushed, mounting holes 32 mm.

Optional:

- Wheels aluminium Alcoa Dura-Bright 32 mm

Driveline

MX engine: 12.9 litres, 6 cylinder diesel engine. Engine performance according to ECE R24-03: output 375 kW (510 hp) at 1500-1900 rpm. Torque 2500 Nm at 1000-1410 rpm. Max. ambient temperature 38 degrees Celsius, Heavy Duty; exhaust emission Euro 5; manual Roadranger gearbox, 18 speeds; rear axle ratio 4.10; mechanical inter-axle and cross-axle differential locks. ASR.

Optional:

- MX300, 300 kW/408 hp, 38C HD.
- Cab badge: 410
- MX340, 340 kW/462 hp, 38C HD.
- Cab badge: 460
- Engine idle shutdown, 5 minutes
- AS-Tronic gearbox, 16 speeds
- AS-Tronic gearbox, 12 speeds

Brake system

ZF Intarder. The ZF Intarder is a hydrodynamic secondary retarder system, integrated in the gearbox. Maximum braking power 500 kW; dual circuit full air brake system. Disc brakes front, drum brakes rear. Twin cylinder air compressor with heated air dryer, 670 l/min at 10 bar. Rear axle load sensing valve.

Optional:

- MX Engine Brake

Chassis

Side member height 260 mm, thickness 7.0 mm. Full length inner reinforcement; 1 circuit steering system; silencer at the right-hand side of the chassis, batteries at the left-hand side; exhaust discharge to the right-hand side; aluminium fuel tank 340 litres, height 620 mm; catwalk with step, standard length. Closed section between the main chassis members approx. 60 cm long; front underrun protection (FUP), according to EU directive 2000/40/EEC; AdBlue tank 45 litres.

Optional:

- Exhaust discharge upward

Drawbar and trailer equipment

Pneumatic trailer connection with C-type couplings; independent trailer valve; electric trailer connection 24V with two 7-pin sockets, lighting cable with 7-pin connectors, EBS cable with 7-pin connectors.

Bodies and preparations for bodying

Connector for analogue engine speed control on the cab front bulkhead. Control functions for engine speed adjustment, programmed engine speed selection, application speed limiter and remote engine start/stop; Bodybuilder module light; application connector for body functions on the cab front bulkhead. Electric signals for -Cab tilt locked- and -Engine running-. Power supply 24 V before and after contact. Spare wiring to the dashboard.

Power take-off (PTO)

Analogue gearbox PTO control, no gearbox PTO. Includes a PTO switch on the dashboard and a PTO control valve on the chassis. PTO connector on the cab front bulkhead with input signals for PTO engagement or disengagement and signals for PTO status indication and PTO warning.

Electrical power supply

Alternator 80 A, batteries 2x 175 Ah.

GVM and GCM

Technical GVM max 25600 kg; technical GCM max. 58000 kg class 2.

Application conditions

Coolant filter; unheated moisture separator with pre-filter; air intake with cyclonic pre-filter behind the cab.

Optional:

- Air intake on the cab roof

Service and maintenance

Standard Warranty takes care of 1 year complete vehicle, 2nd and 3rd year driveline.

Vehicle delivery

Standard toolkit.

Depending on the vehicle configuration a specific option may not be possible. The availability and specification of this vehicle may differ per country. For further information please contact the DAF organisation.
Subject to modification without prior notice.